

Project _____
Item _____
Quantity _____
FCSI Section _____
Approval _____
Date _____



Broaster[®] Undercounter Freezer



Standard Features

- High performance refrigeration, superior cabinet construction, and unsurpassed insulation make this undercounter freezer the perfect accessory to any kitchen.
- Slides easily under work counters, maximizing space for frozen food storage in the kitchen.
- Guided airflow provides uniform temperatures in a 360o circle throughout the cabinet which makes it ideally suited for Broaster[®] Recipe frozen foods as well as any other frozen items, such as ice cream, pizzas, frozen vegetables, and more.
- Self-contained system, no plumbing required.
- Two long lasting adjustable, vinylcoated wire extra-deep shelves (23.5" x 17.5") for greater storage capacity.
- Minimum wattage heater in cabinet frame and door eliminates condensation at lowest energy rate.
- Automatic evaporator fan motor delay during defrost cycle prevents warm air from circulating until coil cools down.
- Recessed handle enhances this freezer aesthetically and functionally.

Specifications

1/3 H.P. Compressor, 6.5 Cubic Feet Capacity,
2 Wire Shelves Standard, Energy Saving Plug-In
Installation, Shelf Size: 23 ¼" x 17 ½"

Exterior Dimension: 27 ½" W x 30" D x 36" H

Voltage/Cycles: 115/60, Amps: 7.0, Power Cord
Length: 7 feet, Crated Weight: 184 lbs.



Broaster® Undercounter Freezer

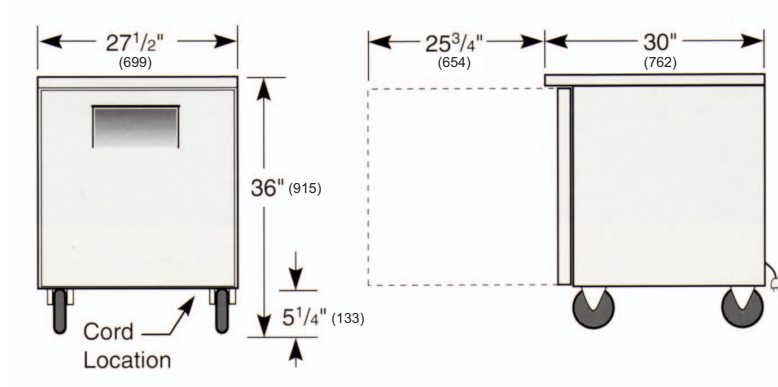

Dimensions in () are millimeters.



The “perfect partner” to our VF-3 ventless fryer.

Dimensions

Overall Dimensions			Net/Ship Weight	Cubes
W	D	H		
27.5"	30"	36"	184/190 lbs. (75.8 kg)	6.5
(699 mm)	(762 mm)	(915 mm)		

Energy Requirements

115v, 60 hz, 7.0 amps, 7' long electrical cord

Additional Features

- Unsurpassed foamed-in-place high density polyurethane insulation (CFC Free) is extra dense and has highest R factor on the market for superior energy efficiency.
- Time-initiated, time-terminated defrost system minimizes energy consumption and provides the shortest possible defrost cycle.
- White aluminum interior, coved corners, and stainless steel floor allow easy cleaning and sanitation. Aluminum finish back minimizes dirt accumulation. All stainless steel front, top, and sides ensure durability.
- Front breathing allows side by side alignment with other units, or placement within optional utility tables (shown above).
- Positive seal, self-closing door swings within cabinet dimensions.
- 5" swivel casters are standard.
- Large condensate pan provides automatic water evaporation.
- -10°F temperature is maintained using environmentally-friendly R404A refrigerant.